



KOMPTEL KFT
1105 Budapest, Vaspálya u. 20.
<https://mac3.hu>



ENGLISH

Made in ITALY

Catalogue

2022

Innovation ■

■ **Reliability**

Know how ■

■ **Human values**



ALL OUR PRODUCTS ARE 100% MADE IN ITALY

OUR RANGE OF PRODUCTS

**LEVEL
REGULATORS**

**CONTROL
PANELS
AND LEVEL
CONTROLLERS**

**BOOSTING
SYSTEMS**

**VARIABLE
FREQUENCY
DRIVES**

**CHOOSE THE PUMP AND
LEAVE THE REST TO US**

Market sectors

Applications

RESIDENTIAL

Boosting systems and Pools

INDUSTRIAL

Level Controllers

IRRIGATION

Clear Water and Sewage

AGRICULTURE

Renewable Energy

REFERENCES

MAC3 is synonymous around the world with high technology and reliability. The wide range of products offered, which is the result of extensive technological and applicative research, covers all liquid control systems. This is the reason that leading companies in the plumbing industry have chosen us as a supplier.

GRUNDFOS 



WILO

Pumpen Intelligenz

EBARA

calpeda

DAB
PUMP PERFORMANCE

PEDROLLO
... the spring of life

FLYGT
a xylem brand

NOCCHI
Pentair Water

LOWARA



MAC3 began with the production its namesake float switch. In the following years the range was extended to cover all areas: clear water, sewage water, drainage, tanks, wells, etc. Together with float switch, MAC3 offers a wide range of devices:



Level Regulators

Level Regulator with electro mechanical equipment

The level regulator is a float switch that allows electrical equipment to start and stop automatically (usually pumps, but also solenoid valves, alarms, etc.) when a prefixed level has been reached. A microswitch that is inside the device turns the contact that powers the pump on and off, depending on the level of the liquid. The models with cable 3X1 or cable 4G1 can be used for the filling or emptying function according to the cables that have been connected.

MAC3 CABLES

all cables supplied with our floats are produced in compliance with a Mac3 specification and are subjected to an acceptance test which ensures their flexibility.

Device:

Electromechanical level regulator based on microswitch.

Application:

main application is control of pumps, filling or emptying, dry running protection.

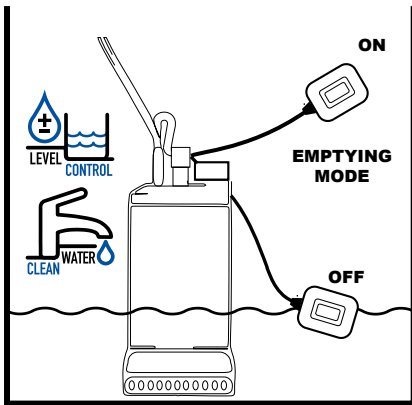

Typical application of a float switch in filling and emptying mode.

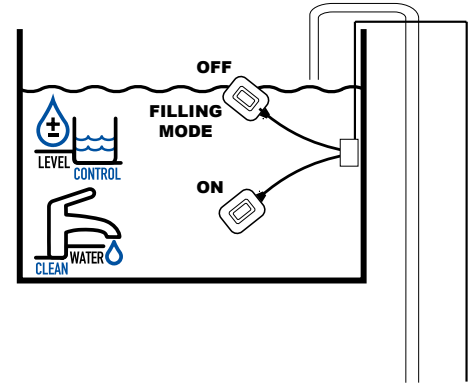

Application: Professional installations and industrial buildings. Any project that requires a high standard of quality and safety.

Advantages: MAC3's historical first float switch, a device with a double liquid-proof chamber for maximum reliability.

Benefits: Large Dimensions to allow a bigger buoyancy and an edgeless shape which is also suitable for sewage water. Dual operation for filling and emptying.



Microswitch electrical features	16(4)A 250V ~ , 20(8)A 250 V~
Approval	ENEC/CE 10(4)A 250V ~ , 10(8)A 250V~
Operating Temp.	0°C ÷ + 50°C
Storage temp.	-10°C ÷ + 60°C
Switch angle	IP 68
Switch angle	+20°/-45°
Dimensions	mm 106 x 154 x54
Weight	gr. 234
Volume	cm³ 384
Max depth level	1 bar
Container	Non-toxic polypropylene(PP)
Dyes	Non- toxic Non- toxic
Standard cable	PVC 3X1 H07RN-F 3G1 H07RN-F 3X1 H07RN-F 4G1
Note	When ordering please specify if needed for filling or emptying function

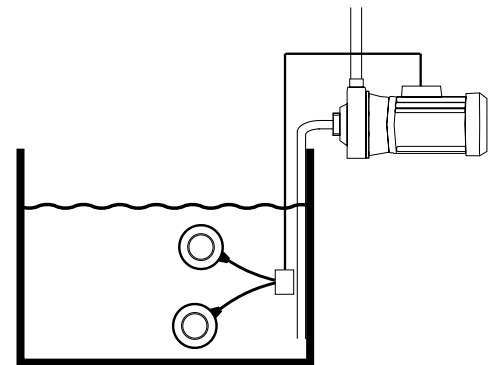

Small



Application: The most popular onboard drainage pumps. The most widely used by electric pump manufacturers that are mounted on their products directly in the factory.
Advantages: Its essential feature is that it is small in size and is highly reliable.
Benefits: It has a high breaking capacity, with the microswitch 20Amps. Dual operation for filling and emptying.



Microswitch electrical features	20(8)A 250 V~ 20(8)A 250 V~ 10(6)A 400 V~ (multivoltage)
Approval	ENEC/CE 10(8)A 250V~ 10(8)A 250 V~ 10(6)A 400 V~ (multivoltage)
Operating Temp.	0°C ÷ + 50°C
Storage temp.	-10°C ÷ +60°C
Switch angle	IP 68
Switch angle	±45°
Dimensions	mm 82x111x48
Weight	gr. 113
Volume	cm³ 179
Max depth level	2 bar e 5 bar
Container	Non-toxic polypropylene(PP)
Dyes	Non- toxic
Standard cable	PVC 3X1 H07RN-F 3G1 H07RN-F 3X1
Note	When ordering please specify if needed for filling or emptying function

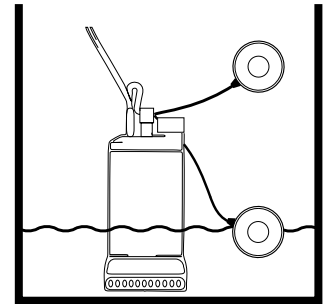

Available IECEX approved version

Key

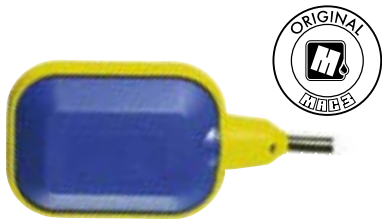

Application: It is the most universally used float switch in the world for the automation of pumps and in storage tanks.
Advantages: Due to its size makes it the most versatile for any application.
Benefits: It is highly reliable and can be produced in many variations in accordance with the needs of each client and country. Dual operation for filling and emptying.



Microswitch electrical features	16(4)A 250V ~ , 20(8)A 250 V~ 20(8)A 250 V~ 10(6)A 400 V~ (multivoltage)
Approval	ENEC/CE 10(4)A 250V ~ , 10(8)A 250V~ 10(8)A 250 V~ 10(6)A 400 V~ (multivoltage)
Operating Temp.	0°C ÷ + 50°C
Storage temp.	-10°C ÷ +60°C
Switch angle	IP 68
Switch angle	±45°
Dimensions	mm 81x131x41.5
Weight	gr. 154
Volume	cm³ 243
Max depth level	1 bar
Container	Non-toxic polypropylene(PP)
Dyes	Non- toxic
Standard cable	PVC 3X1 H07RN-F 3G1 H07RN-F 3X1 H07RN-F 4G1
Note	When ordering please specify if needed for filling or emptying function

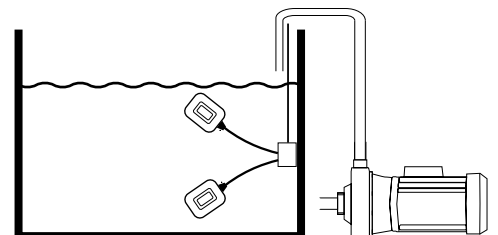

Level regulator for sewage water.

Tilting level regulators were designed specifically for sewage water. Normally used in the control panel, for lifting station, the device can be also installed directly on pumps.

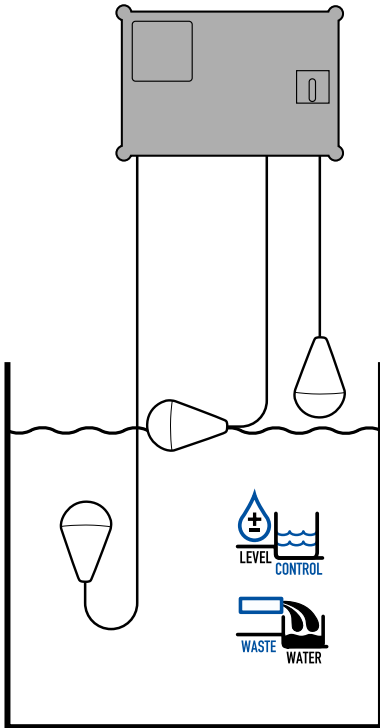

Tilting level regulators for the emptying of a sewage tank.

Mac 5



Application: It has a heavy body, which is also bulky and free of any irregularity, making it ideal for use in sewage water, in industrial waste water with suspended agglomerate residues and in tumultuous water.

Advantages: Made with a double liquid proof chamber and counterweight built into the body of the float.

Benefits: Available with switch angle standard $\pm 10^\circ$ and also with a wider one. **ALSO AVAILABLE ATEX VERSION**

Microswitch electrical features	10(3)A 250 V~
Approval	ENEC/CE 10(3)A 250V~
Operating Temp.	0°C ÷ + 50°C
Storage temp.	- 10°C ÷ +60°C
Switch angle	IP 68
Switch angle	$\pm 45^\circ$ or $\pm 10^\circ$
Dimensions	mm 117x222 (Øxh)
Weight	gr. 1100
Volume	cm ³ 1000
Max depth level	2 bar
Container	Non-toxic polypropylene(PP)
Dyes	Non- toxic
Standard cable	PVC 3X1 H07RN-F 3X1 H07BN4F 3X1
Note	ATEX version available

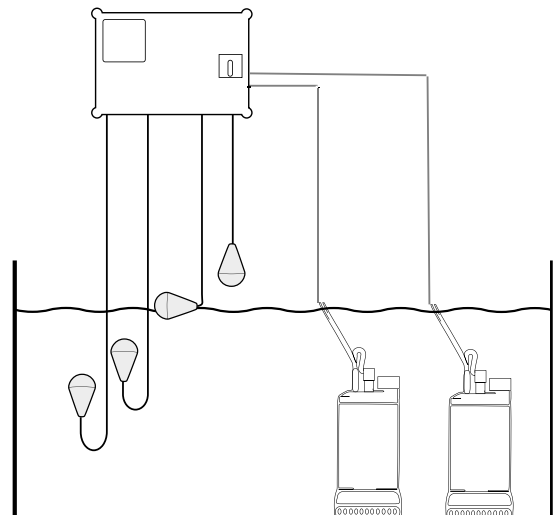

E-Fly



Application: It's body has a smaller size, compared to Mac 5, without edges, suitable for use in small tanks for disposal of sewage water.

Advantages: Made with a double liquid proof chamber and counterweight built into the body of the float.

Benefits: Available with different types of cables, suitable for different applications.
ALSO AVAILABLE ATEX VERSION

Microswitch electrical features	10(3)A 250 V~
Approval	ENEC/CE 10(3)A 250V~
Operating Temp.	0°C ÷ + 50°C
Storage temp.	-10°C ÷ +60°C
Switch angle	IP 68
Switch angle	±10°
Dimensions	mm 100x156 (Øxh)
Weight	gr. 700
Volume	cm³ 620
Max depth level	2 bar
Container	Non-toxic polypropylene(PP)
Dyes	Non- toxic
Standard cable	PVC 3X1 H07RN-F 3X1 H07BN4F 3X1
Note	ATEX version available

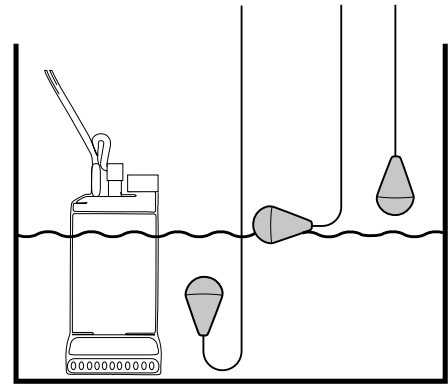

Staffa



Metallic bracket for installation up to 4 regulator as Mac5 or E-Fly.

Weight	gr. 500
Dimensions	mm 37,4 x 9 x 7
Material	Galvanized steel

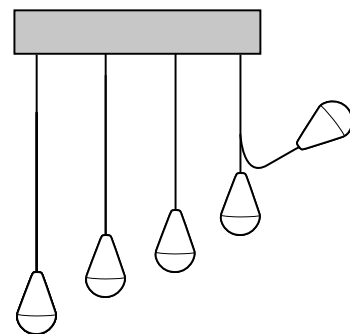

Compact level regulators for applications in small wells

In some applications there is not enough space for a float switch. Moreover, it might be necessary to implement very compact installations with precise levels of intervention. MAC3 offers the following devices for these applications:

Device:

Very compact regulator with limited differential.

Application:

Particularly suitable for very small wells, where a traditional float switch would not have enough room to work.

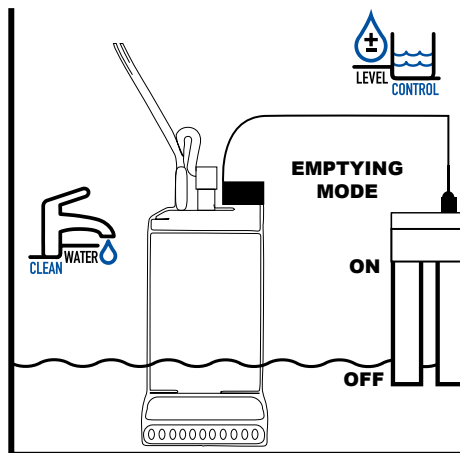
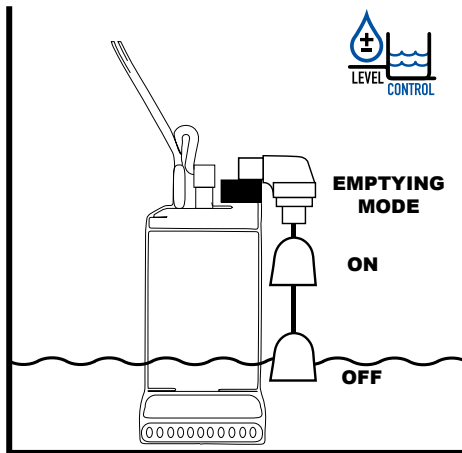

Level Regulators for small tanks, usually used in emptying mode.

Reka

LEVEL CONTROL

CLEAN WATER

RESIDENTIAL & DOMESTIC

CIVIL & INDUSTRIAL

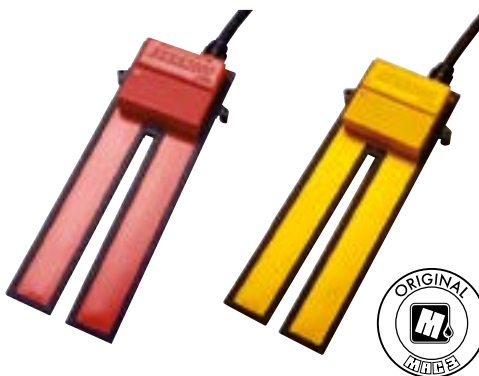

Application: Particularly suitable when there is not enough space for the movement of a traditional float.

Advantages: For its operation uses a capacitive sensor, integrated in the plastic structure, that makes it suitable for a wide range of liquids. It can be operated by battery or electricity and thanks to an internal relay 10(4)A it is able to control pumps with up to 1 HP.

Benefits: It can be easily installed near the pump through the two holes in the structure. The models with 12V or 24V power supply with delay ON/OFF, are particularly suitable for marine use.

Output Relay characteristics	250V 10(4)A
Power Supply	12/24Vcc-Vca 117Vca 230Vca
Rigid. Dielectric	1500V
Differential	cm 9 ±1 (for water)
Approval	CE EN60730
Operating Temp.	0°C ++ 50°C
Storage temp.	-20°C ++ 80°C
Switch angle	IP 68
Dimensions	mm 93X250
Weight	gr. 240
Container	Non-toxic polypropylene(PP)
Dyes	Non- toxic
Delayed version of nautical	0 ÷ 8 sec
Standard cable	H07RN-F 4G1
Max depth level	0,2 Bar

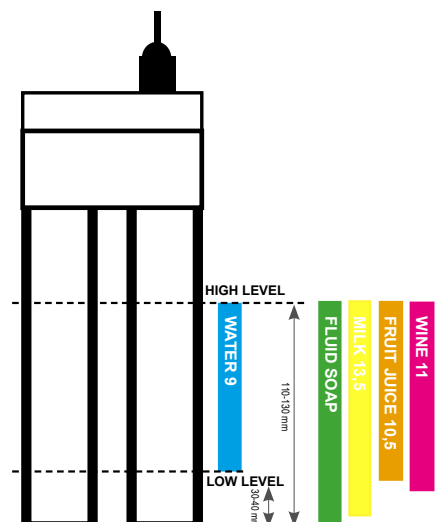

Agma 22



Application: Very compact device usually installed onboard sewage pumps. Two versions for clear water (Agma22) and water with debris (AgmaW).

Advantages: The level controller Agma 22 is a patented device with magnetic coupling. The micro is placed in an upper chamber completely sealed, which ensures a long life to the device.

Benefits: The model AgmaW is also available with flame-retardant cables; the model AgmaW allows the adjustment of the levels of intervention. If it is not possible to use a tilting float, AgmaW can also be used in the presence of waste water, with a periodical verification and cleaning of the mechanisms of buoyancy.

Microswitch electrical features	20(8)A 250 V~
Approval	ENEC/CE (mod. B) CE (mod. A)
Service	Continuous
Differential switching	cm. 7-8
Operating Temp.	0°C + + 50°C
Storage temp.	-10°C + +60°C
Switch angle	IP 68
Pressione max utilizzo	0,5 bar
Dimensions	mm 37x100x226.5
Weight	gr. 300
Container	Non-toxic polypropylenePP/PC
Dyes	Non- toxic
Standard cable	H07RN-F 3G1 (mod. B) H07RN-F 2X1 (mod. B) 2 PVC flame-retardant cables (mod. A) 3 PVC flame-retardant cables (mod. A)
Note	Mod. B Also available UL approved Version is also available with a manual selector

AGMA 22



W



Microswitch electrical features	20(8)A 250 V~
Approval	ENEC/CE
Service	Continuous
Differential switching	cm. min5-max15
Operating Temp.	0°C + + 50°C
Storage temp.	-10°C + +60°C
Switch angle	IP 68
Pressione max utilizzo	0,5 bar
Dimensions	mm 60x235 (Øxh)
Weight	gr. 270
Container	Non-toxic polypropylenePP/ABS
Dyes	Non- toxic
Standard cable	H07RN-F 3G1 PVC 3x1 H07RN-F3X1
Note	Also available UL approved

AGMA W

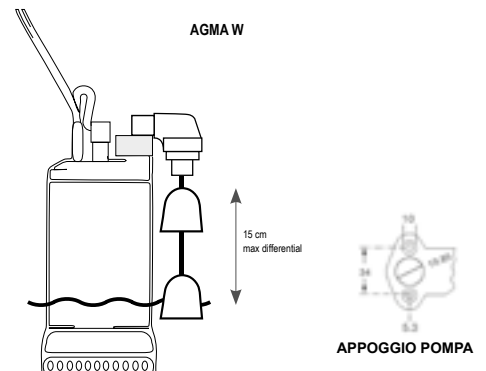

Piggy back plugs



Upon request, all MAC3level regulators may be equipped with a piggy back plug. The piggy back plug is connected to the power supply and receives the pump's plug so that the pump power is controlled by the float.

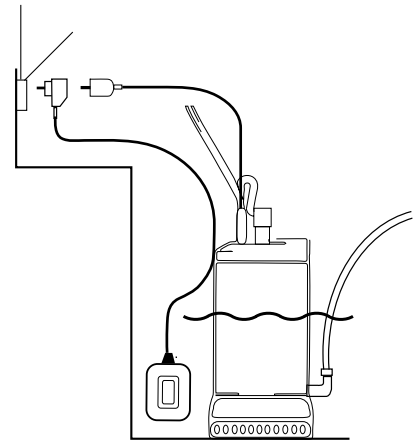
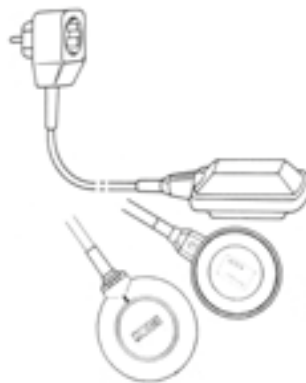

Electronic Level Monitors

Used in storage tank system for monitoring the water level.

Device:

Electronic device for water level monitoring, with acoustic and visual alarms.

Application:

Used to drive control systems and generate alarms based on the level of liquids.



Device that displays the water level in storage tank.

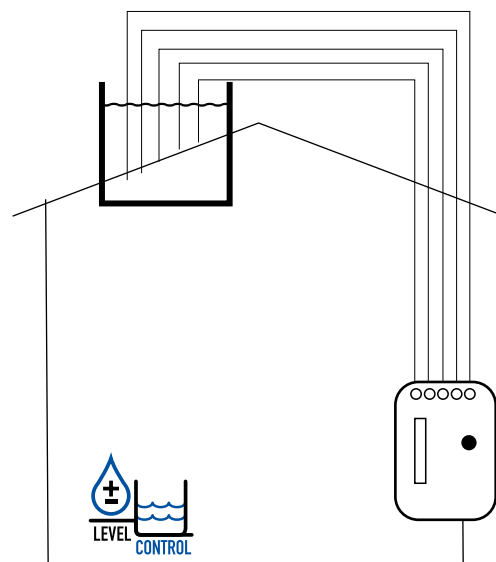

Mac Nivel



Application: This product allows us to view the water level present in a storage tank.
Advantages: Based on the principle of the probes, the device, powered by a battery, applies a voltage across the wires inserted in the terminal block. These wires are positioned into the tank.
Benefits: Easy to install on a wall thanks to the support provided. The LED bar allows a simple and intuitive reading of the water reserve.

Power Supply	9V Battery
Approval	CE
Operating Temp.	0°C + + 50°C
Storage temp.	-20°C + + 80°C
Dimensions	mm 106x80x30
Weight	gr. 70
Container	ABS

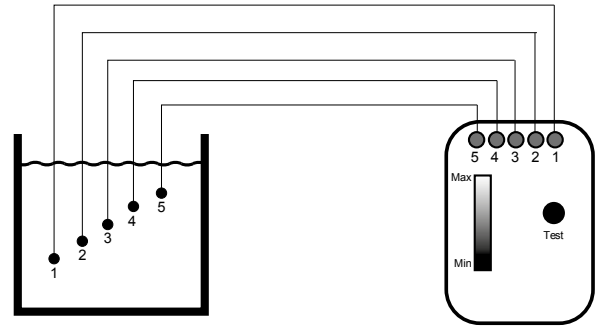

Sentinel



Application: Connected to a level controller, allows acoustic signals according to the level of the liquid.
Advantages: The product is equipped with an output relay with free contacts, to activate an alarm signal at a distance. The relay works only when the device is powered on the network.
Benefits: When the level regulator closes the switch, Sentinel 2 activates its internal buzzer and activates any alarm connected to the relay.

Power Supply	230 V~ 50 + 60 Hz
Back up battery	9 V - 110 mA (Ni-MH)
Output Relay characteristics	0,5A a 250 V~
Current at command IN	13 mA max
Consumption	1 VA
Charging current	13 mA
Holding current	3 mA
Buzzer Approval	yes
Approval	CE
Operating Temp.	0°C + + 50°C
Storage temp.	0°C + + 60°C
Dimensions	mm 105x55x46(64)
Weight	gr. 160
Container	ABS
Notes	Other voltages upon request

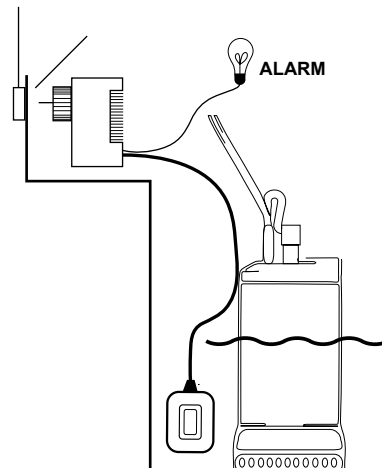

Hydraulic level regulator.

Hydraulic valves are normally used to open/close a water inlet pipe in order to maintain a prefixed level inside a storage tank.

Device:

Hydraulic valve for the opening and closing of pipes.

Application:

Used in storage tanks in order to keep a reserve of water.



Hydraulic valve installation for the filling of a storage tank.

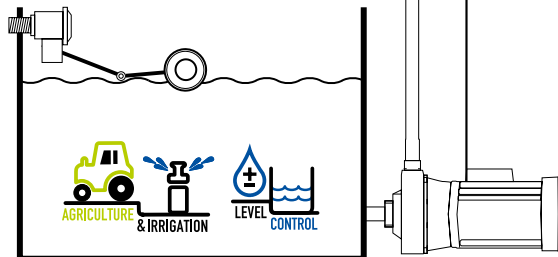

Quickstop Std



Application: Patented hydraulic regulator that eliminates the classic defects of such devices. Especially suitable for filling storage tanks or cisterns.

Advantages: The working mechanism is patented, the jointed arm allows opening and closing instantly by ensuring a high flow and avoiding dripping water.

Benefits: A wide range from 3/8" to 1 1/2" and two versions: Standard and Advanced (ADJ). The ADJ version has adjustable intervention levels, the adjusting mechanism is very simple and versatile and acts on the corner of the joint and on the length and angle of the arm.

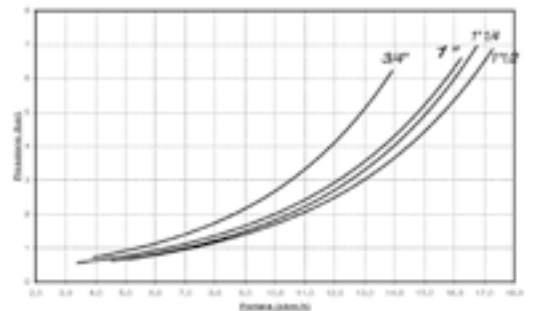
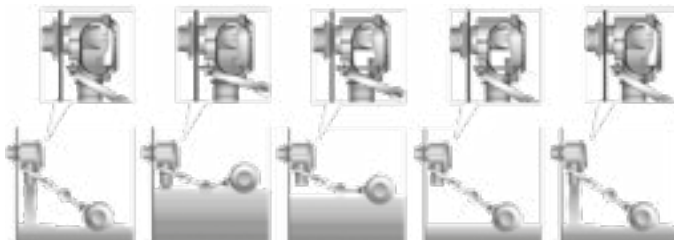

Adj



Operating Temp.	0°C + + 50°C
Storage temp.	-20°C + + 80°C
Overpressure	10 bar
Service	Continuous
Working pressure	0,2-6 bar
Container	Non-toxic polycarbonate
Screws	Stainless Steel
Equipped with input filter	
Dimensions	240x80x50 mm (mod. 3/8", 1/2") 350x150x70 (mod. 3/4" -> 1 1/2")
Thread	BSP (mod. 3/8" -> 1 1/2") NPT (mod. 3/4" -> 1 1/2")

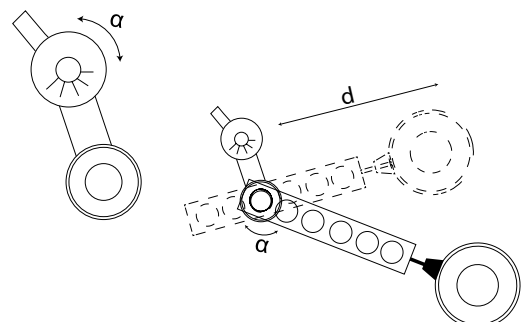

Accessories and special executions

In addition to the standard production, MAC3 has available a line of accessories, which are useful in installations, and some special productions. In special productions some devices carry the CE mark and not ENEC approvals. Some special cables do not meet MAC3 standards and therefore the size of the diameter and the mechanical characteristics of flexibility cannot be guaranteed.

Counterweight



A device used to determine the level regulator excursion point, it is inserted directly onto the cable.

Code	CONTR	CONTRP
Weight	Di serie gr. 220	gr. 300
Dimensions	Ø 47X55	Ø 47X55
Material	Anti-impact polystirene	Anti-impact polystirene
Standard colour	yellow	yellow
Filling material	sand iron grit	iron grit



Special Cables



When the float switch operates with temperatures higher than 60°C we recommend H07BN4-F cable that is suitable for temperatures up to 90°C. This cable is also suitable for use in chemically aggressive environments. In any event, we advise that tests should be carried out in order to determine the exact degree of resistance under your specific conditions.

Micro



When the float switch operates with electronic devices such as personal computers or PLC, the current on the microswitch is very low. MAC3 offers a particular type of microswitch, with gold contacts, for such low currents:

- AC: up to 0,1(0,05)A max 250V ~
- DC: 1mA ÷ 100mA voltages 5V- ÷ 24V

You can also request execution with microswitches suitable for controlling pumps powered by solar panels (DC current)

Approvals



MAC3 can provide level regulators with special approvals:

- UL/CSA for North American market
- ACS for drinking water
- SASO for Saudi Arabian market
- ATEX explosion-proof

	Class	Certificate
MAC3	II	SASO
	I/II	ACS
KEY	II	SASO
	I/II	UL
SMALL	I/II	CSA
	I/II	UL
	I/II	CSA
Mac5	I/II	IECEX
	II	SASO
	I/II	ATEX version
E-Fly	I/II	ATEX version

Level Controller

Device:

Electronic device for controlling levels.

Application:

Level control and measurement in storage tanks or wells.



Boosting system with 2 alternating pumps with a control panel.

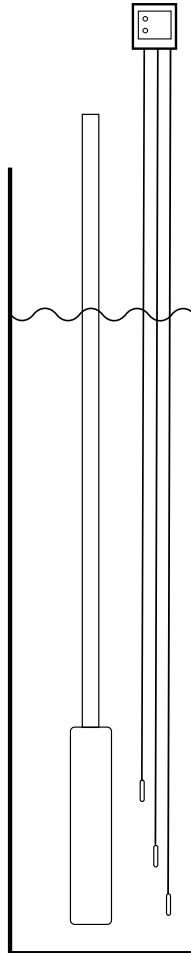

Level Controller

In some applications, there is not enough space for a float switch to control the water level. A suitable solution for this problem are the level probes.

The electro probes, produced by MAC3, are regulators of conductive fluid that control minimum and maximum levels of deep well, tanks, cisterns, etc.

The operating principle is based on the detection of fluid resistance on the part of the control unit, the level being controlled by means of special probes immersed in the liquid, with the longest acting as a common element.

When the level of the liquid inside the container or the well wets all three submersed probes a relay is activated and subsequently deactivated only when the level descends, uncovering the lower probe.



Electroprobe Q



Application: Level controller with DIN rail mounting.

Advantages: A wide range for every need.

Models NS [standard sensitivity]

Particularly suitable to control water and liquids for a total resistance of 5.6 ohm max. The control unit can have a 1000 m. distance from the probes. The use of NS provides an outstanding operational reliability, being insensitive to humidity which is very common in wells and tanks.

Models AS [high sensitivity]

To control liquids with low conductivity, for example rainwater, the AS type is particularly suitable. These models allow liquids with a very high total resistance up to 70 Kohm, to be controlled.

Models SR [adjustable sensitivity]

For the control of conductive liquids with unknown conductivity this model is essential which controls up to 100 Kohm.

Benefits: Easy to install and the experience of MAC3ensures ideal operation for use in water systems.

Power supply	24 - 117 - 230 - 380-415 V~ 50 ÷ 60 Hz
Inter electrode voltages	10 V~
Power consumption	Max 4 VA
Operating resistance	5,6 KΩ (NS) 70 KΩ (AS) 0÷100KΩ (SR)
Mounting	on DIN rail
Output characteristics	250V 5(2)A
Dielectric strength	2000 V
Adjustable start time delay	- 10°C ÷ + 50 °C
Operating temp.	- 20°C ÷ + 80 °C
Container	Noryl (PPO) UL 94 V0
Protection rating	IP20
Approval	CE
Dimensions	90x54x59 mm
Weight	200 gr.
Max cable length of probes	70 ÷80 (AS-SR) m 1000 (NS)
Upon request 2 DIN modules are available DIN rail for supply voltage from 24V - 117V - 230V	

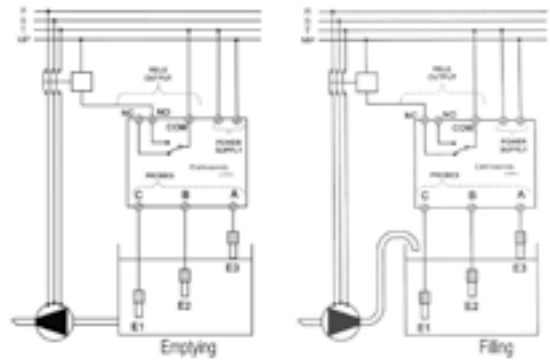

Electroprobe EV



Application: Level controller with DIN rail mounting.

Advantages: The EV model guarantees the SR model flexibility, the NS model performance and moreover, it also allows one to:

- set a delay in the activation of the relay from 0÷16s
- select the kind of intervention to the relay (filling or emptying function).
- request a relay output with 2 exchange contacts in 3 module DIN version.

Benefits: High tech device with a micro controller and an adjustable sensitivity that permits the setting of an adjustable start time delay and has a multi-voltage power supply.

Power supply	24 - 117 - 230 - 380-415 V~ 50 ÷ 60 Hz
Inter electrode voltages	10 V~
Power consumption	Max 4 VA
Operating resistance	0 ÷ 100 KΩ
Mounting	on DIN rail
Output characteristics	250V 5(2)A
Dielectric strength	2000 V
Adjustable start time delay	0 - 16 sec.
Protection rating	- 10°C ÷ + 50 °C
Operating temp.	- 20°C ÷ + 80 °C
Container	Noryl (PPO) UL 94 V0
Protection rating	IP20
Approval	CE
Dimensions	90x54x59 mm
Weight	200 gr.
Max cable length of probes	m 1000
Upon request 2 DIN modules are available DIN rail for supply voltage from 24V - 117V - 230V	

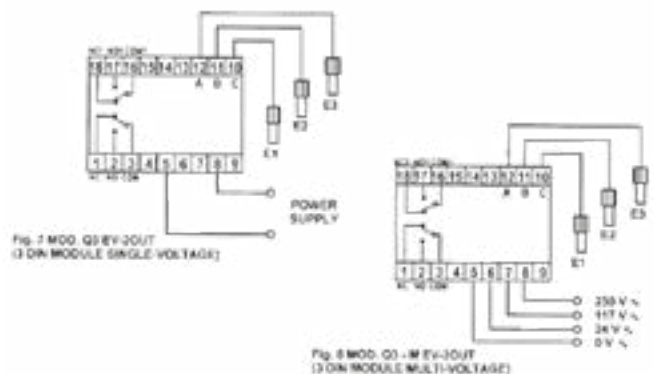

Electroprobe Z8-Z11



Application: Level controller with base DIN socket mounting.

Advantages: A wide range of models for every need. Both the Z8 and Z11 models are available in the three versions: normal sensitivity (NS), high sensitivity (AS) and adjustable sensitivity (SR).

Benefits: The electroprobes of the Z series are particularly interesting because of their reduced size. The Z11 model has a double voltage supply.

WIRING DIAGRAM Z11

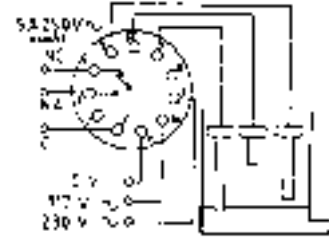

WIRING DIAGRAM Z8

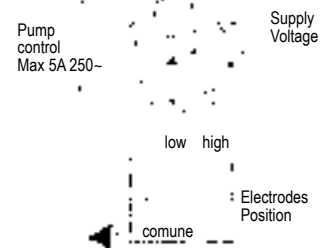

Power supply	24 - 117 - 230 - 380-415 V~ 50 + 60 Hz
Inter electrode voltages	10 V~
Power consumption	Max 5 VA
Operating resistance	5,6 KΩ (NS) 70 KΩ (AS) 0+100KΩ (SR)
Mounting	on socket
Output characteristics	250 V5(2)A
Dielectric strength	2000 V
Response time	100 ms
Protection rating	- 10°C + + 50 °C
Operating temp.	- 20°C + + 80 °C
Container	Noryl (PPO) UL 94 V0
Protection rating	IP20
Approval	CE
Dimensions	79x35x88 mm
Weight	200 gr.
Max cable length of probes	m 70 + 80 (AS-SR) m 1000 (NS)

Application: A multifunctional device used in the field of level control instruments.

Advantages: A multifunctional innovative product which unites a series of functions in a very small space (4 DIN modules):

- ON-OFF electroprobe (operating in one single point/area): acts on relay 2 using probes 6 and 12.
- Differential electroprobe (operates between two probes positioned by the installer): acts on relay 1 using probes 10 and 11, always together with 6 and/or 7 as is common.
- High alarm: use probes 9 and 6.
- Low alarm: use probes 8 and 7.
- Internal Buzzer: For high and low alarms.
- Control for external alarm (buzzer or light).

Benefits: Easy to use with the possibility of activating or deactivating controls by means of dipswitch. The installation of 4 standard electroprobes would be necessary to obtain the same functions.



Power supply	230 V~ 50 + 60 Hz
Inter electrode voltages	24 V~
Power consumption	Max 10 VA
Operating resistance	0 - 20 KΩ
Release resistance	> 20 KΩ
Mounting	DIN bar
Output characteristics	5(2)A 250V
Contact rating alarm relay	AC1 0,5A 250 V ~ resistivo
Response time	100 ms
Protection rating	- 10°C + + 50 °C
Operating temp.	- 20°C + + 80 °C
Container	Noryl (PPO) UL 94 V0
Protection rating	IP20
Approval	CE
Dimensions	90x72x60 mm
Weight	320 gr.
Max cable length of probes	m 20
Power Available	24 V~ - 117 V~



Electroprobe DB



Socket octal



Mounting	DIN bar
Material	ABS
Weight	gr 45
Dimensions	mm 65x40x23
Operating temperature	80 °C max

Triple probe holder

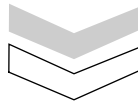
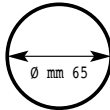

Mounting	Foro Ø mm 65 mm 65
Material	Thermosetting resin
Weight	gr. 190
Dimensions	Ø mm 80x72
Operating temperature	80 °C max
Electrodes mm Ø 3 not included. Protective terminal cover.	

Socket undecal

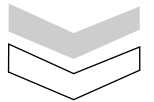

Mounting	DIN bar
Material	Noryl UL 94 V1
Weight	gr 55
Dimensions	mm 65x40x23
Operating temperature	80 °C max

Probe

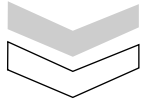

Mounting	direttamente nel liquido
Material	ABS + AISI 316
Weight	gr 45
Dimensions	Ø mm 22x85
Operating temperature	80 °C max



Application: Sensopress is a high technology gauge and electronic level regulator that can be used in sandy drinking water, in liquid foodstuffs.

Advantages: Measurement is made by a very sensitive pressure sensor, whose signal is transformed and processed by a microcontroller and then converted into "water column height", measured in centimeters.*

Benefits: User friendly with a LCD display, on which all the information, relative to the device, is visualized, as well as three function keys for interaction and parameter modification.

*upon request pressure transducer 10 bar is available up to 90 meters, measured in decimeters.

General Technical Data sheet

Power supply	117 V~/ 50+60Hz 230 V~/ 50+60Hz
Power consumption	5,5 VA
Monitoring	LCD 2x16
Field of measurement	0 ÷ 9 m H2O
Max overpressure	20 m H2O
Measuring accuracy	± 1% f.s.
Resolution	1 cm H2O
Minimum obtainable differential	2 cm
Output relay	n°1 (10A 250 V~) + n°3 (2A 250 V~)
Channels	Sensopress n°1 Sensopress4 n°4
Operating temperature	0 °C ÷ + 50 °C
Storage temperature	-10 °C ÷ + 60 °C
Container	NORYL UL 94 VO
Approval	CE
Protection rating	IP 20
Dimensions	mm 105x90x73
Weight	gr. 450
Weight with sensor	gr. 1900

Pressure transducer general technical data sheet for Sensopress LCD

Container	Steel
Operating principles	Monolithic piezoresistive transducer calibrated and tempered
Dimensions	mm 31x120
Weight	gr 1450
Cable	PVC (2 wires + compensation tube)
Cable length	20 mt (as standard)
Installation	Submersible and external
Measurable pressure	0 ÷ 1 bar
Max overpressure	2 bar
Power supply	15 ÷ 30 V 20mA max (from Sensopress device)
Output	4 ÷ 20 mA

It can be used with all types of water with PH between 5+9.
For use with other liquids please consult the factory.

Socket octal



Mounting	DIN bar
Material	ABS
Weight	gr 45
Dimensions	mm 65x40x23
Operating temperature	80 °C max

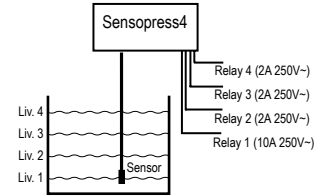
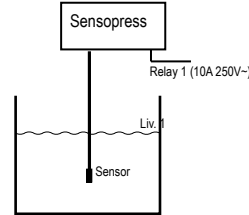

New Software:

- Select pressure transducer 1/10bar
- Select emptying/filling mode
- Setting one or more channels as alarm
- Resect factory setting

Rain Control System

Device:

Electronic system for automatic selection between rain water and main supply water.

Application:

Systems to recycle rain water.

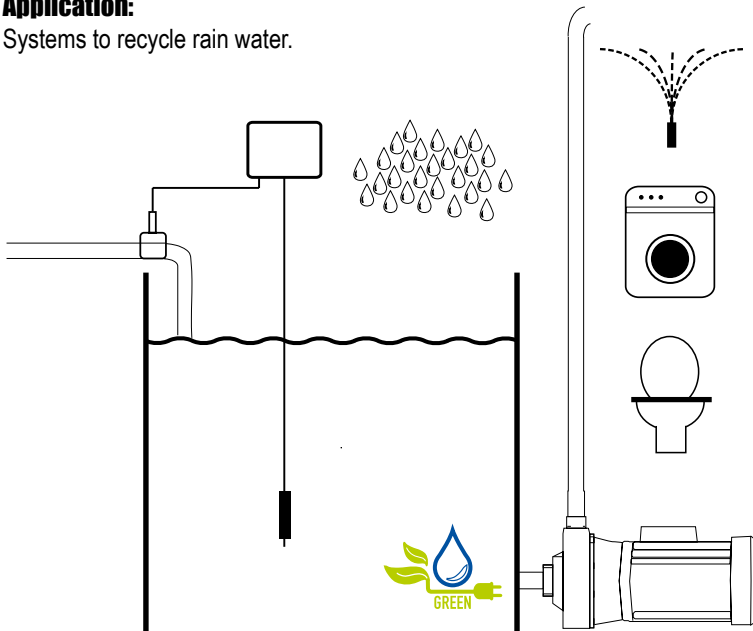

Management and recovery system for rain water.





Electronic level Monitors

Devices used in automatic system form managing rain water.



Application: Device with a DIN rail mounting and LCD Display, for automatic management and control of the use of rain water that substitutes a main supply water.
Advantages: Measurement is achieved by a very sensitive pressure sensor.
Benefits: User friendly with a LCD display, on which all the information relative to the device is visualized.

General Technical Data sheet

Power supply	117 V~/ 50+60Hz 230 V~/ 50+60Hz
Power consumption	5,5 VA
Monitoring	LCD 2x16
Field of measurement	0 ÷ 9 m H2O
Max overpressure	20 m H2O
Measuring accuracy	± 1% f.s.
Resolution	1 cm H2O
Minimum obtainable differential	2 cm H2O
Output relay	10A 250 V~
Channels	n° 1
Operating temperature	0 °C ÷ + 50 °C
Storage temperature	-10°C ÷ + 60 °C
Container	NORYL UL 94 VO
Approval	CE
Protection rating	IP 20
Dimensions	mm 105x90x73
Weight	gr. 450
Weight with sensor	gr. 1290

Pressure transducer general technical data sheet for RainControl LCD

Container	Steel
Operating principles	Monolithic piezoresistive transducer calibrated and tempered
Dimensions	mm 32x76
Weight	gr 840
Cable	PVC (2 wires + compensation tube)
Cable length	5 o 20 mt. (as standard)
Installation	Submersible and external
Measurable pressure	0 ÷ 1 bar
Max overpressure	2 bar
Power supply	15 ÷ 30 V 20mA max (from RainControl device)
Output	4 ÷ 20 mA

It can be used with all types of water with PH between 5+9.
For use with other liquids please consult the factory.

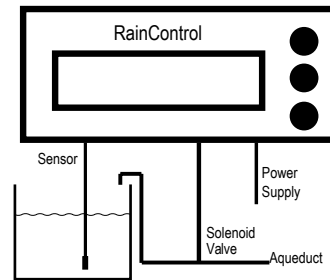

Container for 6 modules

Container for electronic equipment that can be connected to DIN EN 50022 rails according to DIN 43880 regulations. It is available with a 7.5 mm pitch terminal block. It is also available with a hinged front panel in tinted polycarbonate or in PPO RAL 7035.



Container for 2 modules

Container for electronic equipment with input and output terminals on an octal or undecal socket. It can contain one or two printed circuits that can be inserted from the underneath. The front panel can hold leds/lights or displays.



Container for 3 modules

Container for electronic equipment that can be connected to DIN EN 50022 rails. It can contain up to 3 printed circuits. The front panel can hold leds/ lights or displays.



Reducing energy consumption in the world is everyone's responsibility in order to reduce waste. Keeping this in mind, **MAC3** is committed to the development of products for boosting systems that enable low energy consumption. **MAC3** created a research and development program called the "Energy Saving System" which brought about products such as E- Power and HydroController.



Variable Frequency Drives VFD



MAC3 inverters are specifically designed and engineered for water pumps applications. The inverters range divides into 3 sectors of application.

Constant Pressure Systems

Energy consumption reduction, typical of VFD (Variable Frequency Driver) technology, is important and for the end user it leads to costs reduction, but equally important are comfort, improved performances and durability of the system, typical of inverter pumping systems.

- ▶ **CONSTANT PRESSURE** of the system, despite flow variations.
- ▶ **WIDE RANGE** for residential and professional applications up to 25 Amps.
- ▶ **WIFI Support** a connection to HelpDesk web app.



Solar Pumping

Photovoltaic electricity is ideal for pumping water in farms and greenhouses. Our inverters allow the conversion traditional pumping systems into renewable energy systems pumping systems

- ▶ **SOLAR VFD** to drive 3-phase pumps with asynchronous motor.
- ▶ **MAXIMISES** flow rate through available solar energy.
- ▶ **SUN BECOMES WATER** the best solution in using renewable energy of the sun into liquid movement.



Pools with variable speeds

The pools are energy-intensive, the global expense for their management is billions of dollars a year. One of the components of the system with the greatest consumption is the circulation pump. The use of speed variators reduces energy consumption by up to 80%.

- ▶ **ENERGY SAVING** during water filtration.
- ▶ **USER FRIENDLY** installation with webapp.
- ▶ **ALL-AROUND** for new installation or to refit swimming pool pumps.



Constant pressure Systems

Device:

Variable frequency drive for electro-pumps that keeps the pressure of the system constant despite flow variations.

Application:

Used to create boosting systems at constant pressure, replacing the traditional boosting system.



Boosting system with HydroController, up to 8 pumps.
CANBUS communication, pump alternance is guaranteed and MULTIMASTER functionality.

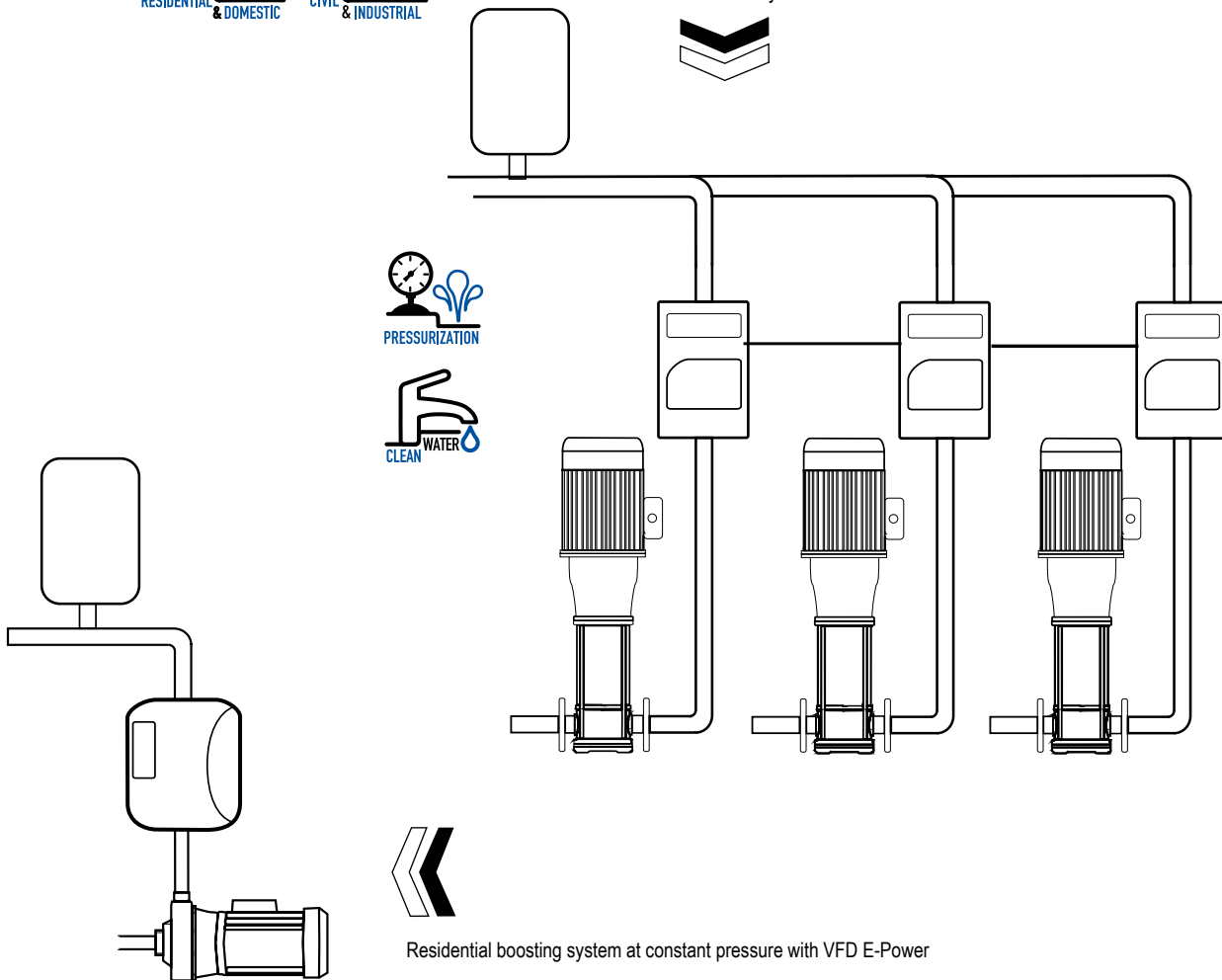

Residential boosting system at constant pressure with VFD E-Power



Variable Frequency Drives

In a water supply system, the demand for a maximum delivery rate is occasional. In fact, there is often the need for variable delivery rates. If a pump works at a variable delivery rate rather than a fixed rate (as in traditional systems) it will work at a moderate rate for most of the time with low energy consumption.

Mac3 range, designed for every need, from the residential system to the shopping center.

Main features are easy-use, extreme reliability and integration with the HelpDesk app, accessible both on the web and with smartphones (**wifi version on request**).



Application: Residential boosting system with constant pressure; VFD specifically developed thanks to the strong experience with the HydroController.

Advantages: Special attention is given to electronic engineering and the realization of functional modern design. The device is mounted on a metal pipe without a valve inside, which permits excellent cooling of the electronics and avoids any flow losses.

Benefits: The installation is directly on the pipe, cooled by water and has a built-in pressure sensor. The device has an ON/OFF input for a float switch or remote control and an output contact relay that can be used as a warning signal or for the realization of a boosting system with a second pump at a fixed rate.

E-Power is a patented product.

New:

web monitoring with wifi connection (**wifi version on request**)

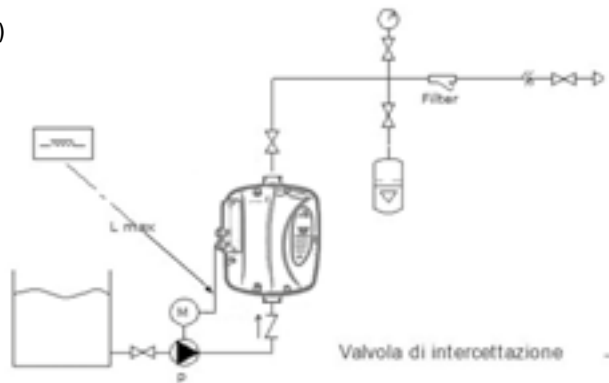

Mounting	on pipe
Mounting position	any
Display	2 digit alphanumeric
Protection rating	IP65
T operating	5÷40°C
Input/Output	1 1/4" male
Output Frequency	5-100hz
Pressure Set Point	0,3-8 bar
Electrical Safety	EN60335
Electromagnetic Compatibility	EN61000 Specific norms in CE certificate
Protection	Dry Running, Low/High Power supply, Short-circuit, Over-current, Over Heating, Insufficient Pressure, Pressure Sensor malfunction, Water hammer
Dimensions	33 x 20 x 15 cm
Weight	2,6 kg



A wide range of models targeted for residential use

The parameters used for its operation are: the desired pressure and the maximum current of the pump. In case of abnormal conditions, E-Power protects the boosting system by automatically switching off the pump; in order to safeguard the water supply, it makes several attempts to reset it.

E-Power is available with a single phase power supply for both single and 3-phase pumps (220V)

Model	Line Voltage	Pump Voltage	Phase Current	Max Pump power	Input	Output	Multipumps
VEPR113 STD	1 x 230Vac	1 x 230Vac	8A	1,1kw (1,5Hp)	1	1	2° ON/OFF
VEPR212 STD	1 x 230Vac	3 x 230Vac	10A	2,2 kw (3Hp)	1	1	2° ON/OFF
VEPR143 ADV	1 x 230Vac	1 x 230Vac	8A	1,1kw (1,5Hp)	1	1	CANBUS
VEPR242 ADV	1 x 230Vac	3 x 230Vac	10A	2,2 kw (3Hp)	1	1	CANBUS

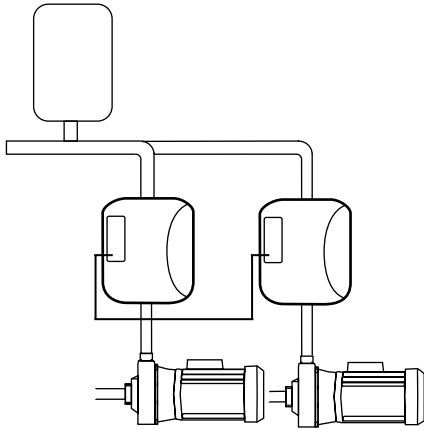

Group 2 - 2 e-power boosting systems, with 2 guaranteed alternating pumps. CANBUS multimaster

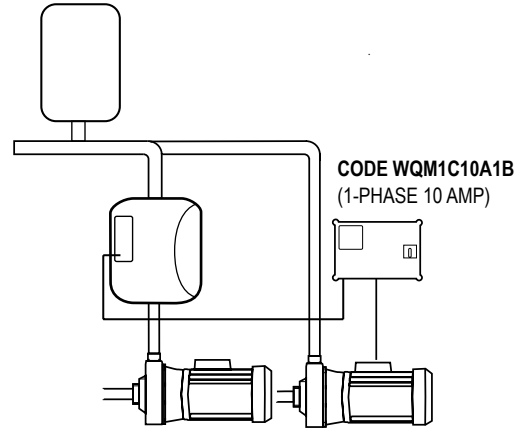

Group 1 - Boosting system with 1 pump driven by E-Power and a second pump ON/OFF piloted by E-Power through a control panel

E-Power All in One



Application: Variable speed boosting pumps for residential use.

Advantages: A captivating design and easy to install. Simple led buttons to set the desired pressure and monitor the pump.

Benefits: Installation is directly on the pump's electrical terminal board thanks to a custom adapter provided on request. The pressure sensor is provided.



Mounting	on electrical terminal board, air cooled
Container material	aluminum
Display	2 digit alphanumeric
Protection rating	IP54
T operating	5+40°C
Input/Output	single phase 230V / 3-phase 230V Imax 8A
Output Frequency	5-100hz
Pressure Set Point	0,3-8 bar
Electrical Safety	EN60335
Electromagnetic Compatibility	EN61000 (Specific norms in CE certificate)
Protection	Dry Running, Low/High Power supply, Short-circuit, Over-current, Over Heating, Insufficient Pressure, Pressure Sensor malfunction, Water hammer
Dimensions	21x23x12cm
Weight	3,3 kg

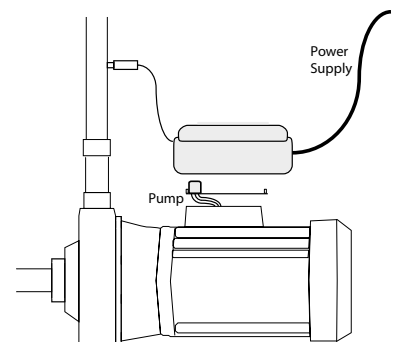

Mac3, always up to date with latest technologies, has developed a remote control and remote assistance system. Initial installation, servicing, monitoring and alarms messages **everything is at your fingertips.**

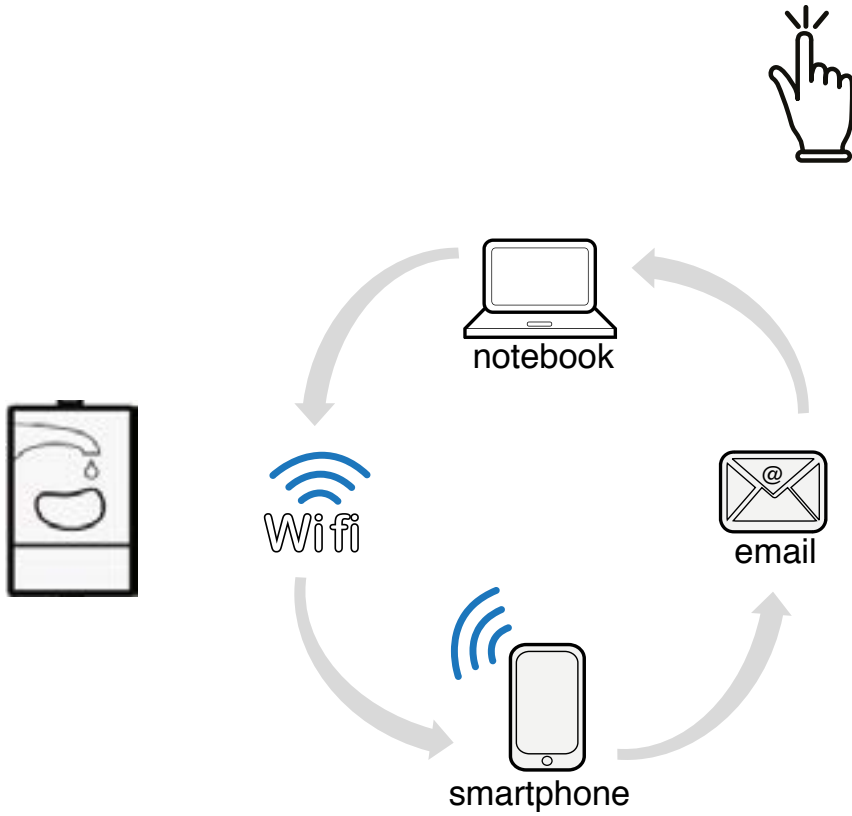

Web System

Remote control and aftersell service. By WiFi connection, the Mac3 inverters can connect to HelpDesk.mac3.it platform via the internet.

- Configuration for the first installation.
- Real-time control with indicators.
- Historical data with graphs and averages.
- Real-time reception of alarms via email.
- Historical view of warnings and alarms.

Add-on function: configuration of the weekly planning for the HcPool version.



End User	Installer
	
<ul style="list-style-type: none"> ▶ Real-time Control ▶ Historical Data ▶ E-mail Alerts 	<ul style="list-style-type: none"> ▶ Quick Configuration ▶ System Monitoring ▶ E-mail Alerts



Web App

Remote control and aftersell service. By WiFi connection, the Mac3 inverters can connect to your smartphone.

- Configuration for the first installation.
- View and update of internal parameters.
- Firmware Update upload.

Add-on function: configuration of the weekly planning for the HcPool version.



Application: A wide range of Professional VFDs with the following options:

- for single pump or multi-pump boosting systems
- air cooled or water cooled models
- available in three versions: single phase power supply for single phase pump, single phase power supply for 3-phase pump and 3-phase power supply for 3-phase pump.

Advantages: User-friendly interface composed of 4 buttons and a display with 16 char-2 lines, for an easy first installation and for managing operation and alarm parameters.

Benefits: The parameters for the first installation are the desired pressure and the maximum current of the pump: these are clearly displayed so that there is no need to read the manual in order to understand them.

In the event of an anomaly, HydroController protects the boosting system by switching off the pump, in order to safeguard the water supply it will undertake automatic or programmed reset attempts.

New:

web monitoring with wifi connection



Mounting	HCW on pipe HCA on wall
Mounting position	HCW any HCA vertical
Display	LCD 2 lines with 16 characters
Protection rating	HCW IP65 (fan IP54)
T operating	5÷40°C
Input/Output	HCW 1 1/4" female
Output Frequency	5-100hz
Pressure Set Point	HCW 0,3-8 bar HCA 0,3-25 bar *please specify, while ordering, if 25 bars pressure transducer is required (standard up to 10bar)
Electrical Safety	EN60335
Electromagnetic Compatibility	EN61000 (norme specifiche nel certificato CE)
Protection	Dry Running, Low/High Power supply, Short-circuit, Over-current, Over Heating, Insufficient Pressure, Pressure Sensor malfunction, Water hammer
Dimensions	MM/MT: HCW 36x19x17cm HCA 40x26x19cm TT: HCW (3-5.5hp) 36x19x17cm HCA (3-5.5hp) 40x26x19cm HCA (7.5hp-15hp) 40x28,5x25,5cm
Weight	MM/MT: HCW 3kg (4kg mod TT) HCA 6Kg TT: HCW (3-5.5hp) 4 Kg HCA (3-5.5hp) 6 Kg HCA (7.5hp) 11 Kg HCA (10hp) 11,5 Kg HCA (15hp) 12 Kg

A wide range of models for all needs

The range of HydroController is divided into the following models:

- HCW water cooled, for in line installation, with built-in pressure sensor and flow sensor.
- HCA air cooled, for wall mounting installation, external pressure sensor supplied as standard.

Available in two versions:

Standard

A basic version that includes all the features and common protections, each device pilots a single pump.

The device has an input for external float switch or remote control ON/OFF and an output relay that can be used as a warning signal or for boosting system with a second pump at a fixed rate.

Advanced

More than the basic version, this model adds more features and allows the realization groups up to 8 pumps (all pumps must be identical). In the multi-pumps mode, the communication is CanBus protocol and guarantees not only the alternation of the pumps but also the option Multimaster (in case of failure of a component in the system it automatically reconfigures itself). In this configuration, the system handles all the pumps used in vAirble speed, increasing/decreasing together with their speeds of rotation.

The Advanced version also integrates the following features:

- Irrigation: The irrigation control unit can be connected to the HC through the Multipress4, with the possibility of setting up to 4 pressures, for different sectors of irrigation.
- 2 Outputs relays
- 2 Auxiliary inputs Specific uses of the inputs and outputs can be arranged with our technical department.



Standard Product 50/60Hz

Model	Line Voltage	Pump Voltage	Phase Current	Max Pump power	In. Float switch	Input	In Irrigation	Output	Multipumps
VHD 113 MM STD	1 x 230Vac	1 x 230Vac	8A	1,1kw (1,5Hp)	1			1	
VHD 143 MM ADV	1 x 230Vac	1 x 230Vac	8A	1,1kw (1,5Hp)	1	2	4	3	x
VHD 114 MM STD	1 x 230Vac	1 x 230Vac	12A	1,6kw (2,2 Hp)	1			1	
VHD 144 MM ADV	1 x 230Vac	1 x 230Vac	12A	1,6kw (2,2 Hp)	1	2	4	3	x
VHD 212 MT STD	1 x 230Vac	3 x 230Vac	10A	2,2kw (3Hp)	1			1	
VHD 242 MT ADV	1 x 230Vac	3 x 230Vac	10A	2,2kw (3Hp)	1	2	4	3	x
VHD 311 TT STD	3 x 400Vac	3 x 400Vac	06A	2,2kw (3Hp)	1			1	
VHD 341 TT ADV	3 x 400Vac	3 x 400Vac	06A	2,2kw (3Hp)	1	2	4	3	x
VHD 312 TT STD	3 x 400Vac	3 x 400Vac	11A	4kw (5,5Hp)	1			1	
VHD 342 TT ADV	3 x 400Vac	3 x 400Vac	11A	4kw (5,5Hp)	1	2	4	3	x
Large systems / Big Plants									
VHD 343 TT ADV	3 x 400Vac	3 x 400Vac	15A	5,5kw (7,5Hp)	1	1	4	2	x
VHD 345 TT ADV	3 x 400Vac	3 x 400Vac	18A	7,5kw (10Hp)	1	1	4	2	x
VHD 346 TT ADV	3 x 400Vac	3 x 400Vac	25A	11kw (15Hp)	1	1	4	2	x

American Version 60Hz

Model	Line Voltage	Pump Voltage	Phase Current	Max Pump power	In. Float switch	Input	In irrigation	Output	Multipumps
HC-TT06-ST	3 x 230Vac	3 x 230Vac	06A	1,1 kw (1,5hp)	1			1	
HC-TT06-ADV	3 x 230Vac	3 x 230Vac	06A	1,1 kw (1,5hp)	1	2	4	3	x
HC-TT11-ST	3 x 230Vac	3 x 230Vac	11A	2,2 kw (3hp)	1			1	
HC-TT11-ADV	3 x 230Vac	3 x 230Vac	11A	2,2 kw (3hp)	1	2	4	3	x
Large systems / Big Plants									
HC-TT15-ADV	3 x 230Vac	3 x 230Vac	15A	3,7 kw (5hp)	1	1	4	2	x
HC-TT18-ADV	3 x 230Vac	3 x 230Vac	18A	4,5kw (6Hp)	1	1	4	2	x
HC-TT25-ADV	3 x 230Vac	3 x 230Vac	25A	5,5kw (7,5Hp)	1	1	4	2	x

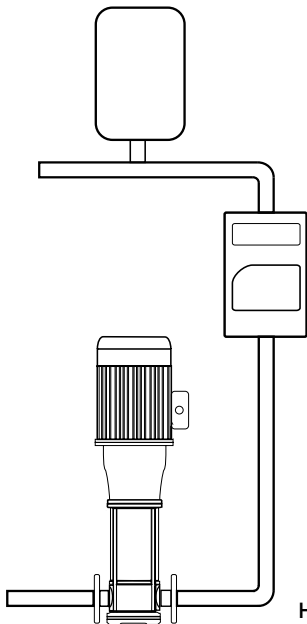

HCW
water cooled and in-line installation

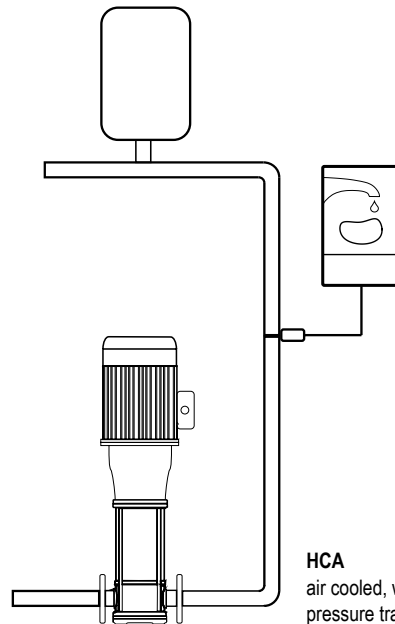

HCA
air cooled, wall mounted with external pressure transducer.

Differential pressure transducer
HCA can be supplied with a differential pressure transducer. Typical applications are air conditioning and heating systems. HydroController ensures a continuous check of pressure or flow to guarantee constant recirculation.



Regulator ON/OFF

Device:

electronic on/ off pump regulator.

Application:

used to create an economical and more compact system instead of a traditional pressure boosting system with an expansion tank

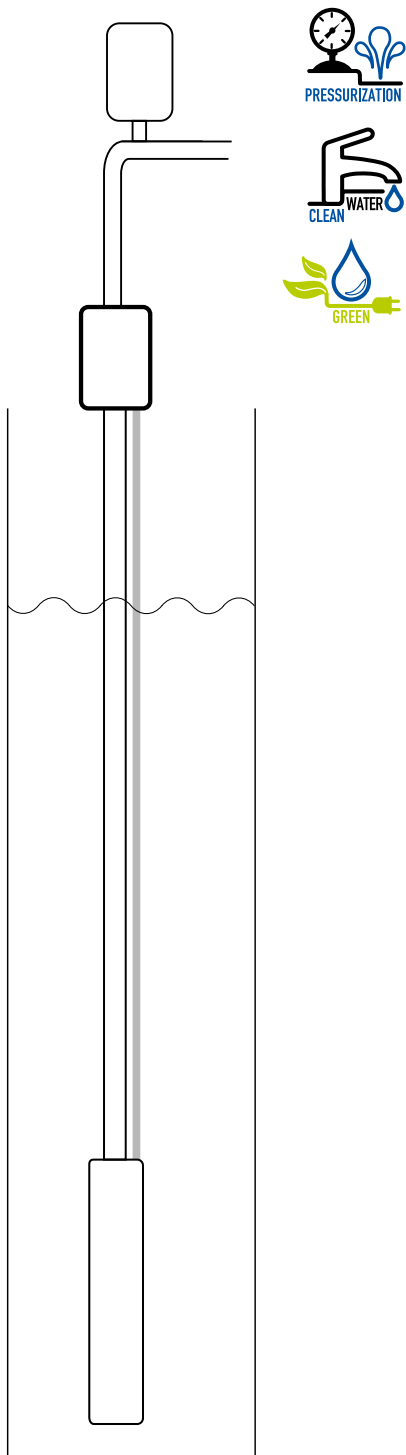

Electronic regulator for submersible pumps. Functions with an electronic pressure switch with ammetric protection to the pump's motor.

Dry running protection with $\cos\phi$ monitoring.





Application: Residential boosting systems with reduced dimensions, replacing the traditional pressure boosting system that uses a pressure switch and an expansion tank.

Advantages: The device is supplied on a metal pipe, with no valve inside, so that there is no flow losses.

Benefits: The installation is directly on the pipe, with a built-in pressure sensor, so that the stop & restart pressure can be regulated.

Mounting	on pipe
Posizione Mounting	any
Protection rating	IP50
T. operating	5°C ÷ 50°C
Input	1" male
Working Pressure	1,5 - 8 bar
Restart Pressure	0,6 - 7 bar
Min. differential pressure	0,3 bar
Max Flow	120 lt/min
Max Overpressure	20 bar
Approval	CE
Material	PP
Pipe	Steel AISI 304
Dimensions	17x23x8,2 cm
Weight	1,1 kg
PresSystem cosφ	
Additional features	
Max Pump Current	12A
Dry running	- Dry running protection by pressure check - Dry Running protections with cosφ check

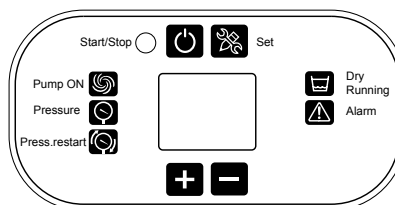

Standard Product 50Hz

Mode	Line Voltage	Pump Voltage	Current	Max Pump Power	Input Float	Dry running
PSS	1 x 230Vac	1 x 230Vac	12A	1,5kw (2Hp)	x	x
PSC	1 x 230Vac	1 x 230Vac	12A	1,5kw (2Hp)	x	X cosφ

American Version DUAL VOLTAGE

Mode	Line Voltage	Pump Voltage	Max Pump Current	Max Pump Power	Input Float	Dry running
PSS	1 x 117/220Vac	1 x 117/220Vac	12A	0,75kw (1Hp)-110V 1,5kw (2Hp) 220V	x	x
PSC	1 x 117/220Vac	1 x 117/220Vac	12A	0,75kw (1Hp)-110V 1,5kw (2Hp) 220V	x	X cosφ



1" Swivel adapter M/F in plastic
Adapter that permits the direct installation on the pump outlet, of MAC3ON/OFF regulator models.
Material Nylon Fiberglass.
Available BSP and NPT version.

Pools with Variable speed

Device:

Variable frequency drive for pool pumps that varies the number of cycles.

Application:

used to reduce energy consumption during the water filtering of a pool.



Hydro **Pool**
controller

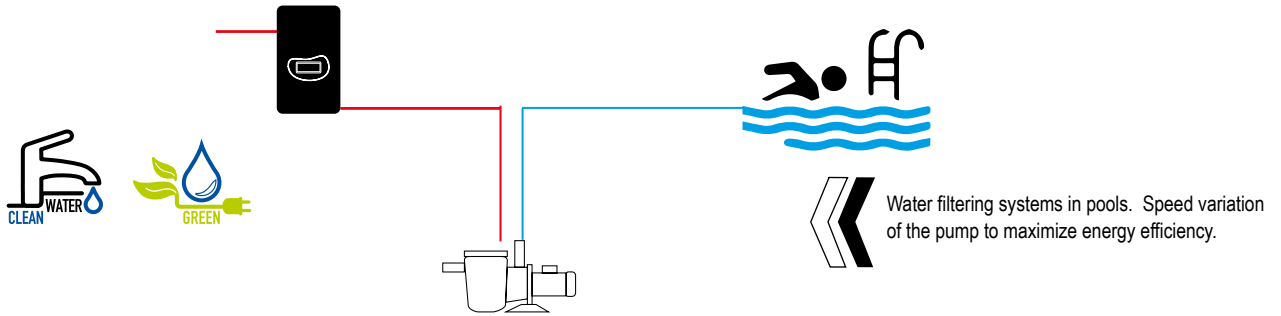

Hydro
Pool

The maximum speed of a filtering pump in a pool is intermittent and in effect, a pump often works at various speeds during the day. The use of the variable speed drive Hydro Pool allows the pump to work at a moderate speed for most of the time, which helps reduce energy consumption.

Inverter (VFD) for pool pumps

HydroController Pool allows us to drive a single-phase and three-phase pump 230v with a single-phase residential power supply and three-phase pump 380V with Industrial power supply.

The system is guaranteed because of its integrated electrical and hydraulic protection.

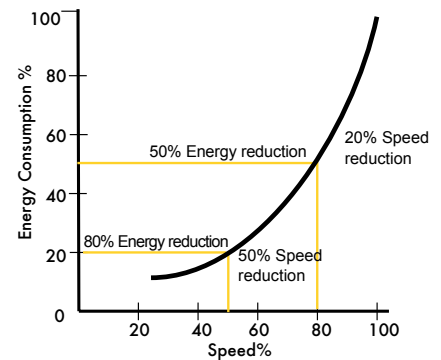

HydroController POOL



Application: A filtering system for pools that use pumps at variable speeds.

Advantages: Easy electric and hydraulic installation. Weekly programming through web monitoring and a smartphone.

Benefits: The possibility to fit a HC drive, in installed electric pumps that don't have inverters and in professional systems with pumps that have a higher power.

Cooling	Air
Position Mounting	Vertical
Display	LCD 2x16
Protection rating	IP65
T operating	40°C
Output Frequency	4 adjustable frequency
Electrical Safety	EN60335
Electromagnetic Compatibility	EN61000
Protection	Low/High Voltage, Short-Circuit, Over-Current, Over Heating
Dimensions	40x26x19 cm
Weight	6kg
Input	5 input wires for external control unit

M Help Desk
WIFI included

A WIDE RANGE OF MODELS SUITABLE FOR ALL POOL PUMPS

Years of experience in the production of inverters has allowed MAC3to produce a line of variable speed drives for pool pumps.

A choice of air cooling devices give you a chance to drive pumps that have been previously installed and high power pumps for Professional systems.

The Advanced version is equipped with a wifi antenna and can be programmed through a P.C. or smartphone.

Model	Line Voltage	Pump Voltage	Phase Current	Max Pump power
HC-MM08-ADV	1 x 230Vac	1 x 230Vac	8A	1,1kw (1,5Hp)
HC-MM12-ADV	1 x 230Vac	1 x 230Vac	12A	1,6kw (2,2 Hp)
HC-MT10-ADV	1 x 230Vac	3 x 230Vac	10A	2,2kw (3Hp)
HC-TT06-ADV	3 x 400Vac	3 x 400Vac	06A	2,2kw (3Hp)
HC-TT11-ADV	3 x 400Vac	3 x 400Vac	11A	4kw (5,5Hp)
Large systems				
HC-TT15-ADV	3 x 400Vac	3 x 400Vac	15A	5,5kw (7,5Hp)
HC-TT18-ADV	3 x 400Vac	3 x 400Vac	18A	7,5kw (10Hp)
HC-TT25-ADV	3 x 400Vac	3 x 400Vac	25A	11kw (15Hp)



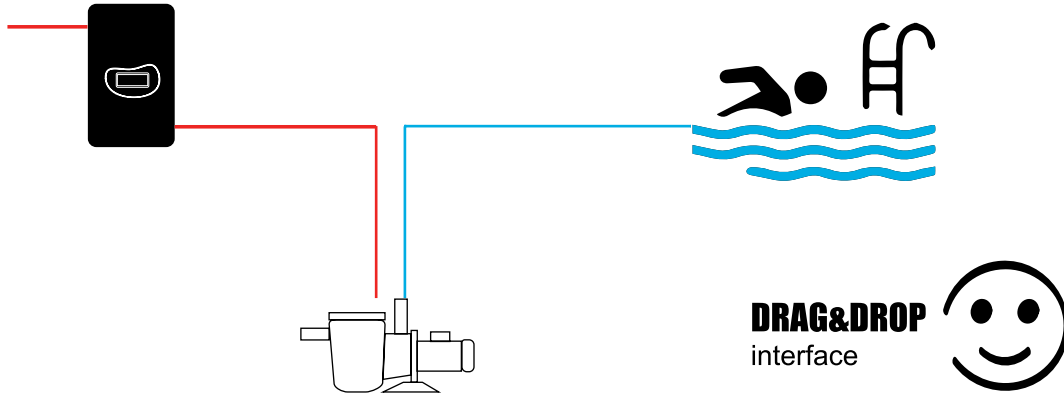

WEEKLY PROGRAMMING

HydroPool is equipped with a wifi antenna. Therefore, it is possible to set up a weekly program through your PC or smartphone.

There are two types of internet connections:

- Internet: Upon initial installation, the device drive can connect to a residential wifi. With your PC or smartphone you can connect through a web app, which allows you to set up a weekly program.
- Point to point connection: Upon initial installation, connect your smartphone to the wifi network generated by the drive, so that through the app you can set up a weekly program.



INTERFACE FOR PROGRAMMING

- Start and Stop programming
- 6 times a day are available
- 4 different speeds
- Duplication of daily programming
- First configuration set up



Solar Pumping

Device:

VFD that drives three-phase electro-pumps with an asynchronous motor through the use of solar modules.

Application:

used to extract water by means of a submersible borehole pump. Maximises the water flow rate through available solar energy.

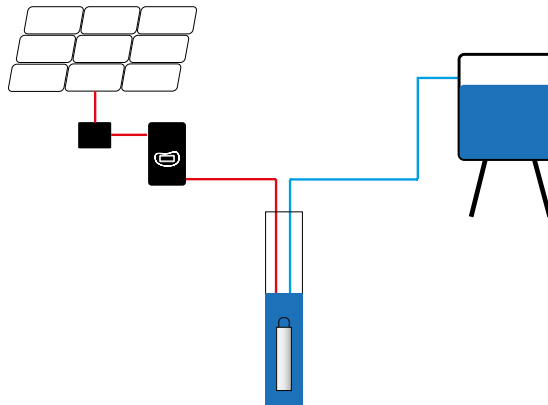

Pumping Solar systems for irrigation by means of renewable energy.

Liquid Sun

Liquid Sun is a collaboration between MAC3 and Fototherm, two innovative Italian companies. Thirty years experience of MAC3 in the plumbing industry supported by the strong FOTOTHERM experience in the renewable energy sector.

We can achieve the best solution in using renewable energy of the sun into liquid movement.

Our slogan is "Sun become water" from which the name LiquidSun derives. Our technological solutions enable us to transfer all the solar energy directly into liquid movement.

Inverters (VFD) pumping systems using Solar Modules

HydroController Solar VFD allows one to drive three phase pumps with asynchronous motor through solar panels. The VFD uses an advanced software that guarantees the maximum water flow rate depending on solar energy available.

The Operating system is guaranteed thanks to the electrical and hydraulic protection integrated in the product.

Our wide range of models vary from 6 to 25 amps to drive pumps from 1 to 15 Hp.

HydroController SOLAR



Hydro controller Solar



Application: Irrigation system with submersible borehole pumps through the use of renewable energy.

Advantages: Particular attention is given to the design of the inverter in order to maximize the transfer of solar energy into the production of water. Extremely easy to install and a user-friendly interface.

Benefits: Possibility to drive traditional three-phase pumps with an asynchronous motor through the use of solar modules.

Cooling	AIR
Mounting position	vertical
Display	LCD 2x16
Protection rating	IP65
T operating	40°C
Output Frequency	0-100hz
Electrical Safety	EN60335
Electromagnetic Compatibility	EN61000
Protection	Dry Running, Low/High Power supply, Short-circuit, Over-current, Over Heating, Insufficient Pressure, Pressure Sensor malfunction, Water hammer
Dimensions	40x26x19 cm (VHSA311 - 312) 40x28,5x25,5 cm (VHSA343 -345-346)
Weight	6Kg (VHSA311 - 312) 11 Kg (VHSA343 -345-346)





Mounting	on pipe
Mounting position	any
Display	2 digit alphanumeric
Protection rating	IP65
T operating	5+40°C
Input/Output	1 1/4" male
Output Frequency	5-100hz
Pressure Set Point	0,3-8 bar
Electrical Safety	EN60335
Electromagnetic Compatibility	EN61000 Specific norms in CE certificate
Protection	Dry Running, Low/High Power supply, Short-circuit, Over-current, Over Heating, Insufficient Pressure, Pressure Sensor malfunction, Water hammer
Dimensions	33 x 20 x 15 cm
Weight	2,6 kg

A wide range of models suitable for all submersible borehole pumps

MAC3 has 10 years of experience in the production of inverters/VFD for pump controllers. Using the models in production we can drive pumps through solar energy.

The heart of the solution is found in the firmware: in addition to the MPPT, algorithms have been developed to optimize the transfer of energy towards the production of water. These wide range of models are composed of Hydrocontroller HCA mounted on walls, cooled by air, for three-phase pumps 230V/380V app to 11Kw (25A)

	HCA TT06	HCA TT11	HCA TT15	HCA TT18	HCA TT25	E-Power
Vout (VAC)	3x230 - 3x400	3x230 - 3x400	3x230 - 3x400	3x230 - 3x400	3x230 - 3x400	3x230
Current	6	11	15	18	25	10
Vin (VDC)	min 150 - Max 650	min 150 - Max 650	min 150 - Max 650	min 150 - Max 650	min 150 - Max 650	min 150 - Max 400

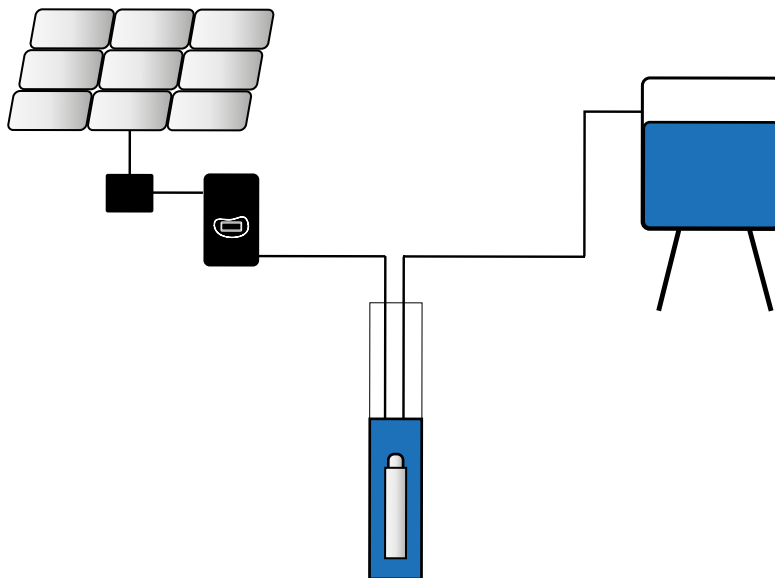

System Sizing

Thanks to a sophisticated program of computer software and keeping in mind the special demands of the irrigation system, it is possible to identify the best kind of installation and minimize the initial economical investment.



Identify the geographical area of the system

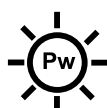
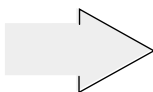

From that GPS position, calculate the amount of solar energy available

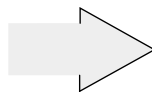

Hydraulic needs: depth of well, water demand

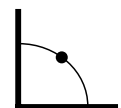
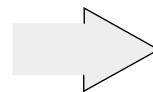

Sizing of the pump and calculation of the amount of solar modules necessary



Mounting	DIN bar
Protection rating	IP20
T operating	0°C + +50°C
Power supply	24V 50-60Hz
Consumption	1 VA
N. pressure selection channels	4
N. solenoid inputs	16 (4xchannel)
Max solenoid input voltage	24V 50-60Hz
Max solenoid input absorbed current	50 mA x channel
Approval	CE
Material	PPO UL94V0
Dimensions	10,5x9x7,3 cm
Weight	0,26 kg

An irrigation system requires different pressures depending on the type of irrigation device used. This entails the use of a pressurized water system designed to support the highest pressure requested. This kind of system DOES NOT optimize on energy saving.

MAC3 offers a VFD pressurisation system which interfaces with all popular irrigation controllers. Simply connect the individual solenoid valve to the irrigation control unit, as well as to the terminal Multipress. At the closing of a solenoid, the VFD is set at the desired pressure. Thanks to Multipress4 and VFD technology you have a pressurization system that provides correct pressure and a power appropriate for the required flow rate.

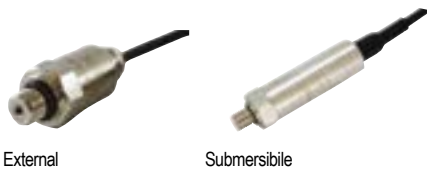
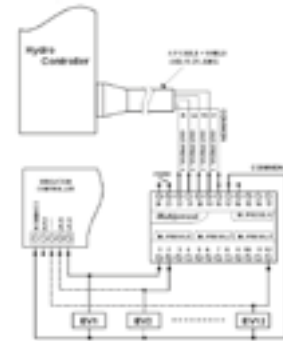

HCA air-cooled drives, comes with a pressure transducer 4-20mA, with a 3 meter cable for external use. In addition to the standard model, MAC3 can supply other models.

Position Mounting	any
Protection rating	IP67 External use IP68 (10bar) submersible
T operating	- 40 - 85°C
Input/Output	1/4" Gas
Power supply	10-30 Vcc (external) 10-36 Vcc (submersible)
Uscita	4-20 mA
Tipo di Cable	Polyurethane shielded/PVC
Accuratezza	+/- 1% fs
Approval	CE
Materiali	Steel

Cable	Description	Code
3 mt	external use 4-20 mA 10 Bar	PRE56C1A8M03H0E
5 mt		PRE56C1A8M05H0E
10 mt		PRE56C1A8M1000E
20 mt		PRE50C1A8M2000E
3 mt	Submersible 4-20 mA 10 Bar	PRS50C1A8M0300E
10 mt		PRS50C1A8M1000E
20 mt		PRS50C1A8M2000E

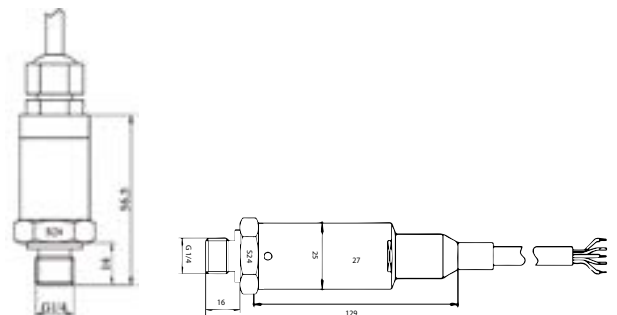

Accessories

ACL Filters



The connection cable between the inverter and pump creates a capacity effect that influences the way in which the VFD drives the pump. To avoid this problem, MAC3 has a wide range of adapters available for long connections (ACL) up to 200mt. We recommend using this product for cable lengths longer than 20 mt. Filters are available for single-phase and three-phase pumps with different currents.

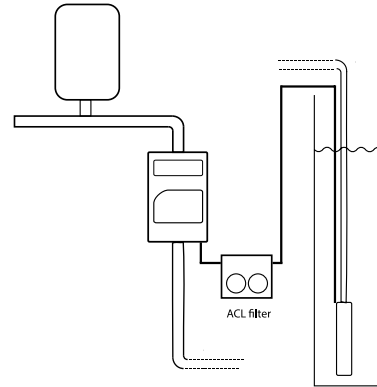

Position Mounting	any
Protection rating	IP20
T operating	0°C ÷ +50°C
Approval	CE
Material	Galvanized steel

Model	Code	Pump Voltage	Current	Fan	Dimensions (cm)	Weight (kg)	Note
ACLM	/900600010	1 x 230Vac	10A		24x14x16	4,5	
ACLM	/900600011	1 x 230Vac	10A	x	24x14x16	4,6	
ACLT	/900600005	3 x 400/230Vac	10A		24x14x16	5	
ACLT	/900600006	3 x 400/230Vac	10A	x	24x14x16	5,1	
ACLT	/900600013	3 x 400/230Vac	16A		24x14,5x18,5	8,5	Low loss / low noise
ACLT	/900600015	3x400/230Vac	30A		24x19,5x20	10Kg	Low loss / low noise

Upon request sinusoidal filter available

Infilter



MAC3 VFD are EMI certified. In areas that are particularly sensitive to electromagnetic interference, MAC3 can supply EMI filters, for single-phase and three-phase pumps with different currents, that can be installed between the inverter and the power supply.

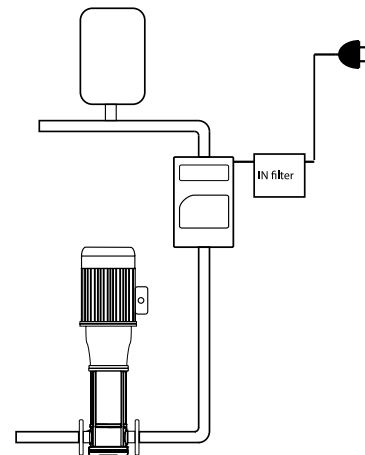

Position Mounting	any
T operating	0°C ÷ +50°C
Approval	CE
Material	Galvanized steel

Code	Pump Voltage	Current Max	Dimensions (cm)	Weight (kg)
/520003000	1 x 230Vac	50A	12x10,5x5	0,75
/520003010	3 x 400/230Vac	20A	10,5x11x8	0,86
/520003040	3 x 400/230Vac	10A	20x7,5x7	0,98
/520003041	3 x 400/230Vac	16A	17x15,5x8	3,8
/520003042	3 x 400/230Vac	25A	13x8,5x9	1,1